

Manual for Uninterruptible Power System



New Concept Intelligent
i UPS

Contents

A. Scope of Application

B. Application Standards

C. Environmental Condition

D. Schematic Drawings and Specifications of Equipment

E. Detailed Explanation for Schematic Drawings and Specifications of
Equipment

F. Electrical Characteristics

G. Inspection Item

H. Material and Structure

A. Scope of Application

This equipment is an uninterruptible, constant-voltage, constant-frequency power system to supply a constant alternating power continuously for the fixed interruption compensation period when the change and interruption of voltage, frequency in commercial power or stand-by power. This equipment can also be applied to the whole field of industry and can provide a safe power control of the load system with the mounted computer communication interface.

B. Application Standards

- * K. S(Korean industrial Standards)**
- * ANSI(American National Standards Ins)**
- * IEE(Institute of Electrical and Electronic Engineers)**
- * Manufacturer's Standard (iUPS Power MonII)**
- * Manufacturer's Standard (ISO9001/KS A 9001)**

C. Environmental Condition

This product may be used in the following environmental conditions. Especially, temperature and humidity may have an important influence to this equipment and reduce its life.

- 1. Ambient Temperature: Less than 0 40 (avoid a disclosed place as possible as and install equipment at a well- ventilated place)**
- 2. Relative Humidity: Less then 90%**
- 3. Installation place : Indoor(this equipment is for indoor installation and must be thoroughly prevented from rain or snow.) The only surface of equipment must be cleaned and wet lag must not be used due to danger of an electric shock. When a computer monitor or TV monitor is at an installation place, install equipment at a distance of 1m or more.**
- 4. Altitude: Less than 1000m**

D. Schematic Drawings and Specifications of Equipment

This equipment consist the following main parts:

- * Rectifying and charging part**
- * Inverter part**
- * Output transformer part**
- * Synchronous cut-down switch part**
- * Control part**
- * Digital display operation panel**
- * Condenser (armoring type)**

E. Detailed Explanation for Schematic Drawings and Specifications of Equipment

* iUPS 2400VA / iUPS 3600VA / iUPS 5400VA / iUPS 7500VA

Summary

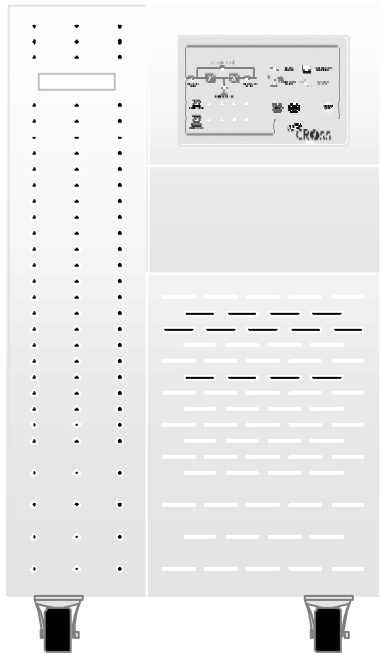

As all types of semi-conductor elements becomes more minimized and precise due to the rapid development of the electronic industry essential for an advanced industry, a mass of loss in the respect of time and economic efficiency have been resulted, such as mis-operation of loading devices, loss or damage of important data due to instability of power (including change of voltage and frequencys,trengthening of instantaneous voltage, surge, temporary interruption). Accordingly, iUPS is a uninterruptible power system that is designed and manufactured so as to use conveniently and that can cleanly remove such instability of power in the sine wave pulse width modulation method as a instantaneous voltage control method by IGBT(Insulated Gate Bipolar, Transistor) which is an advanced electric and electronic technology, and can supply a good quality of power to the loading device in any conditions.

Major Characteristics

IGBT is an advanced electric element that can switch a mass of electric power in a high frequency, and that is solid and is convenient to use and that plays a role of motive power to realize efficiency, low noise, small size and light weight. The IGBT combined the high input impedance and high speed switching performance of the MosFET, and the high conduction characteristics (Low Saturation Voltage) and the high voltage/large current processing power of a bipolar transistor. In addition, since the IGBT controls ON/OFF status with voltage signals, drive circuit becomes simple and consumption power is small.

- Supporting an isolated redundant method (+N) and pursuing a firm reliability of power control.
- Semi-conductor element is composed of in the module method and thus is easy to maintain and can minimize damage of a semi-conductor element.
- Increasing life of a fan and reducing noise by controlling a fan with the temperature sense of the module attached to the temperature sensor.
- Easy to control the operation of equipment with a centralized front display and checking the proper operation of equipment and power status only by pressing a switch.
- Protecting a semi-conductor element with a high-speed fuse for protection of equipment.
- Easy to replace accessories and A/S is very convenient with the PCB as main part attached to the top of equipment.
- In the back side of equipment is a code to supply input power to equipment. Output and battery NFB are placed at the left side of equipment in the solid method. In the right side of equipment, AC 220V consent with four holes are attached for users to easy connect load.

- The battery with the Hot Swappable function (PowerCell Guard + N) is designed easy to maintain and install equipment, and is very convenient since the only connection of a conductor can provide an additional mounting of the battery. With the basic mounting of power Mon II's communication interface, providing safe control of the load equipment for provision of interruption.
- Easy for A/S or maintenance by removing the bolt assembly to the utmost so that removing or mounting of each outside panel is easy.
- The only connection of input power cord provides immediate use and it is convenient to connect the output equipment as two output consents(2 EA) are basically mounted to the back panel.
- Compatible with usual business environment by adopting a revolutionary design of domestic UPS.
- For a simple operation of equipment, the operation key of the front display is simplified. Icon explanation is provides to easily recognize operations of equipment, and the LED illuminating method can provide a remote discernment.

Inside/Outside configuration and arrangement of equipment

1. Outside Configuration

Front View

1. Front display - Easy to handle and discriminate whether equipment operates properly

2. Front display cover

3. Front cover - The fan which is attached to the radiating panel with many ventilating holes in the front cover, operates and absorbs cool air from outside and minimize the inner temperature and temperature of the radiating panel.

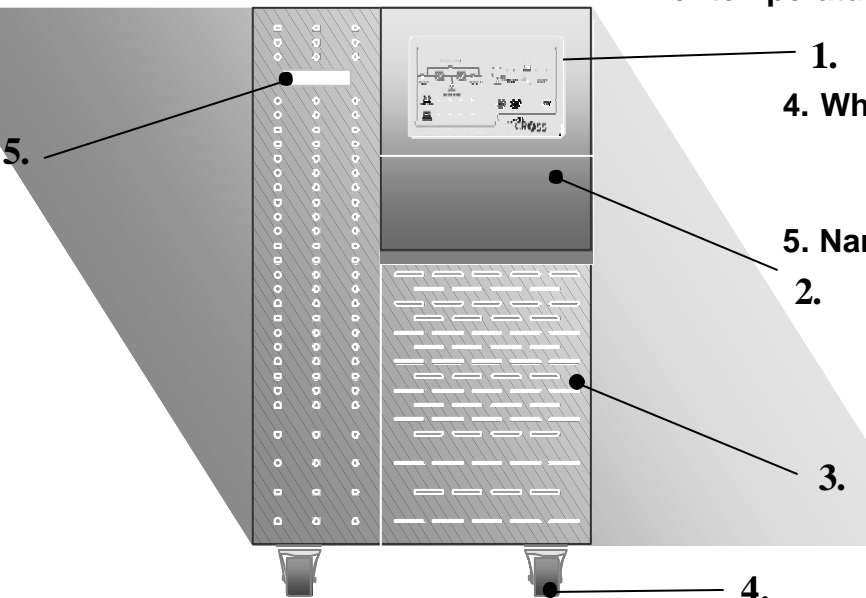

1.

4. Wheel for movement - Easy to install and convey equipment as wheel exists.

5. Name Pleat - The attached name pleat of high-quality epoxy resin provides a high-quality of the machine.

2.

3.

4.

SIDE VIEW

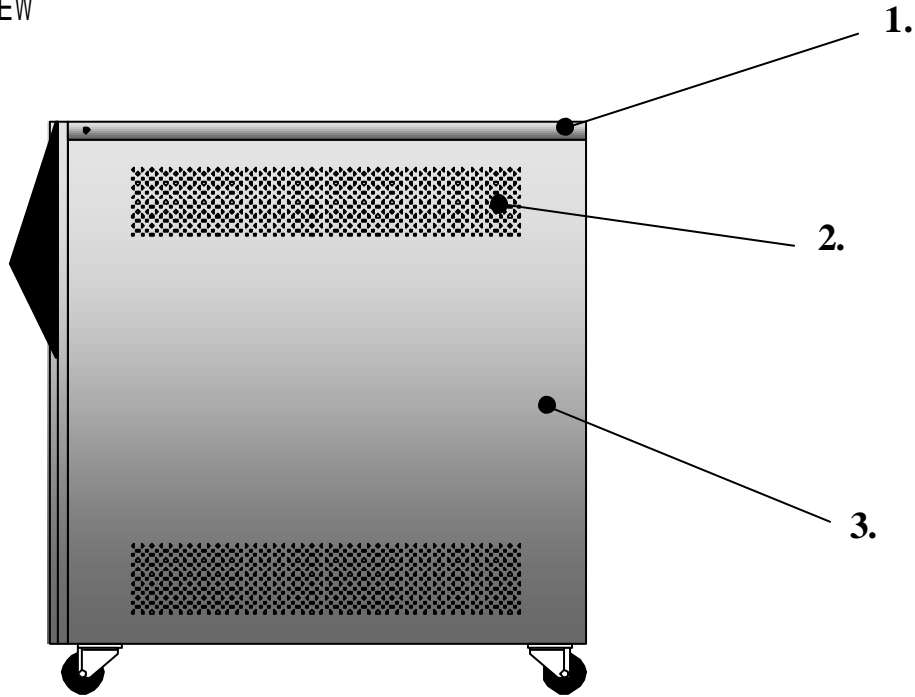

- 1. Top panel - Designed to discharge inner heat to the utmost with the holes made at the both sides.**
- 2. Panel hole at side - Designed to minimize the increase of inner temperature due to the high temperature of inverter (out transformer).**
- 3. Side Door Panel - Easy to remove or attach as no bolts exist.**

Layout of Terminal Console

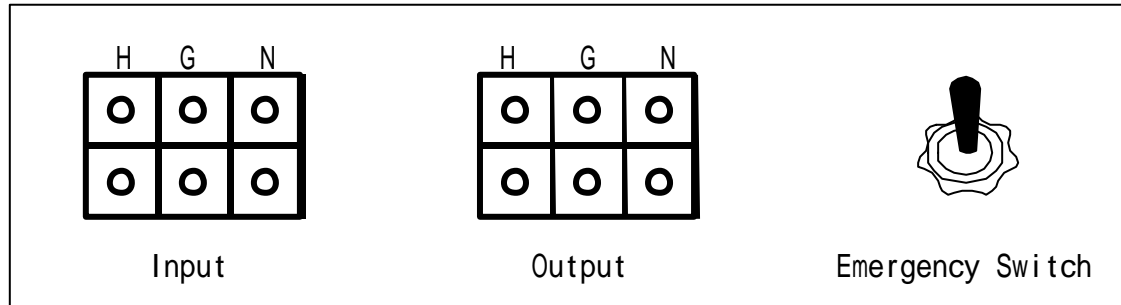

The wiring work of input terminal console is done with a KIV wire and the H-phase of the wiring of input terminal console is discriminated with a red tube and N-phase is discriminated with a blue tube.

The emergency switch is a switch manually cutdown by the bypass in the malfunction of equipment, which is mounted at the back side of equipment. Prohibit operation as operating the switch is dangerous when equipment operates properly.

The work at the output terminal console is done with the KIV wire. For working, the H-phase is discriminated with a red color, the N-phase with a blue color.

Major Inside Configuration of Side View

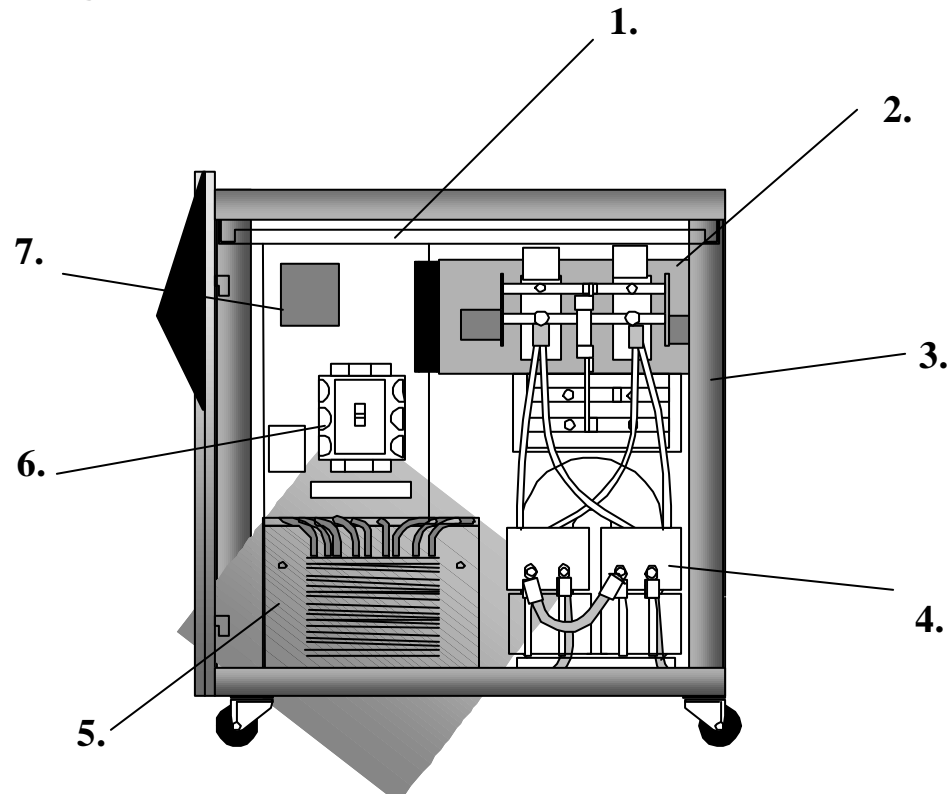

1. PCB Attachment Module - The main control PCB is mounted and A/S can be immediately done if opening the top panel.
2. Inverter & positive conversion part, charge module part.
2. Outside Framework - With 10mm-5mm pitch more than the material tone of 2.3t and the existing model, durability is more improved and arrosion is prevented with the zincing process.
3. Inverter(output) transformer - Manufactured and designed so as to endure heat up to 180 with 11 kinds of compound transformer.
5. Input transformer(compound transformer).
6. Electronic switch.
7. Power Mon PCB - Automatically shut down computer in the interruption with a basic option.

Rear View

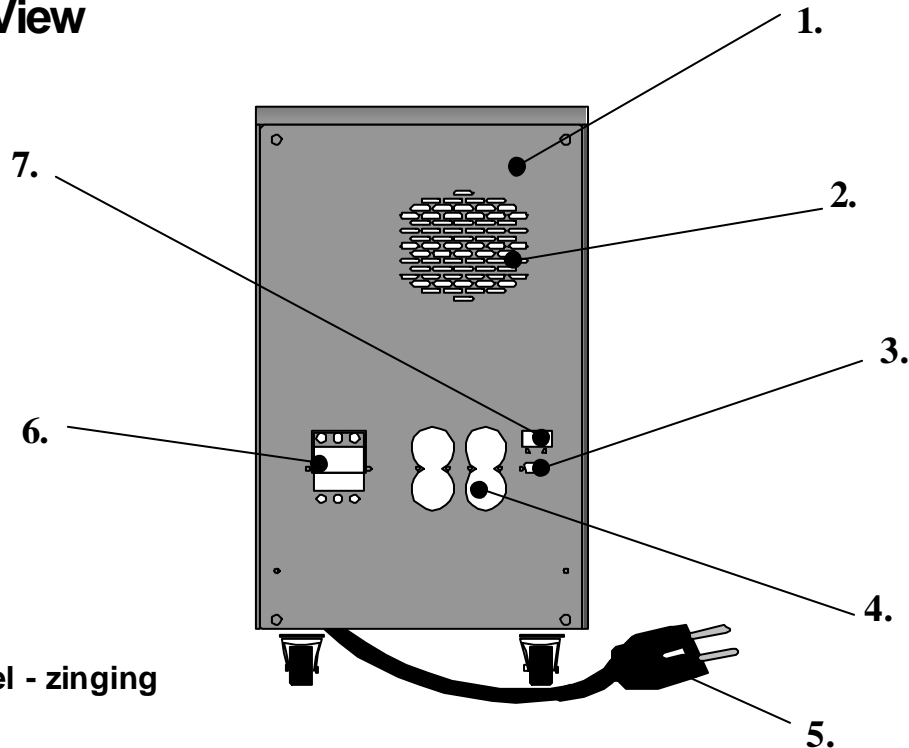

1. Rear Panel - zinging

2. Built-in radiating panel - Holes for discharging heat of a radiating panel

3. Power Mon (Communication Interface Serial Port)

4. Output 220V consent - Easy to connect the load axis as the consent with four holes is mounted.

5. Input code - Easy to install as input is done with a plug.

6. Protecting ups and equipment as the output and battery breaker are mounted.

7. Connecting connector to connect with the Power Cell Guard (Battery).

*** Appearance Drawing in the mounting of a front view battery**

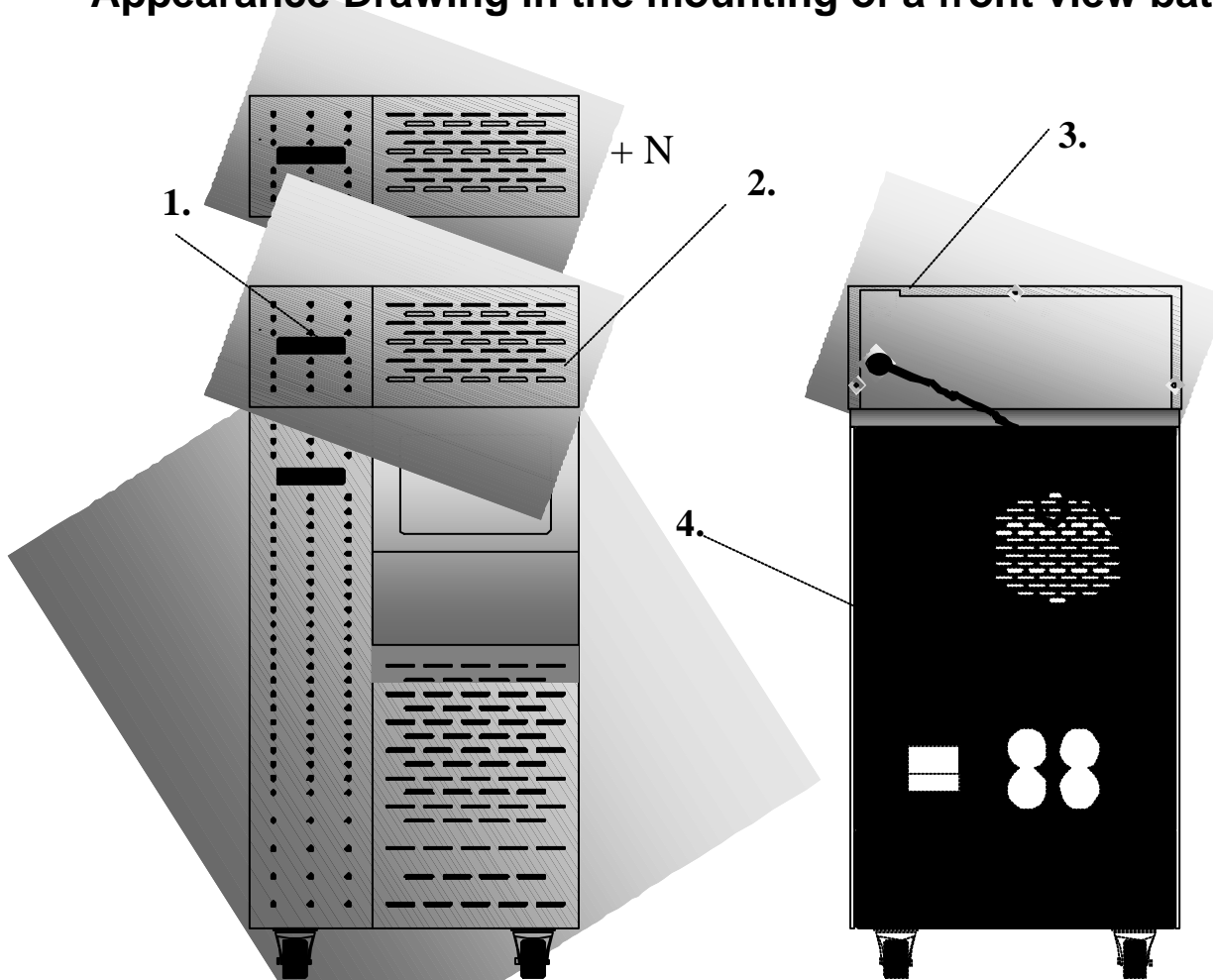

- 1. Power Cell Guard Name Pleat**
- 2. Power Cell Guard - ES 7AH 16CELL mounting + N**
- 3. Connection connector in the extension of backup**
- 4. Connection with Power Cell Guard and iUPS**

Display

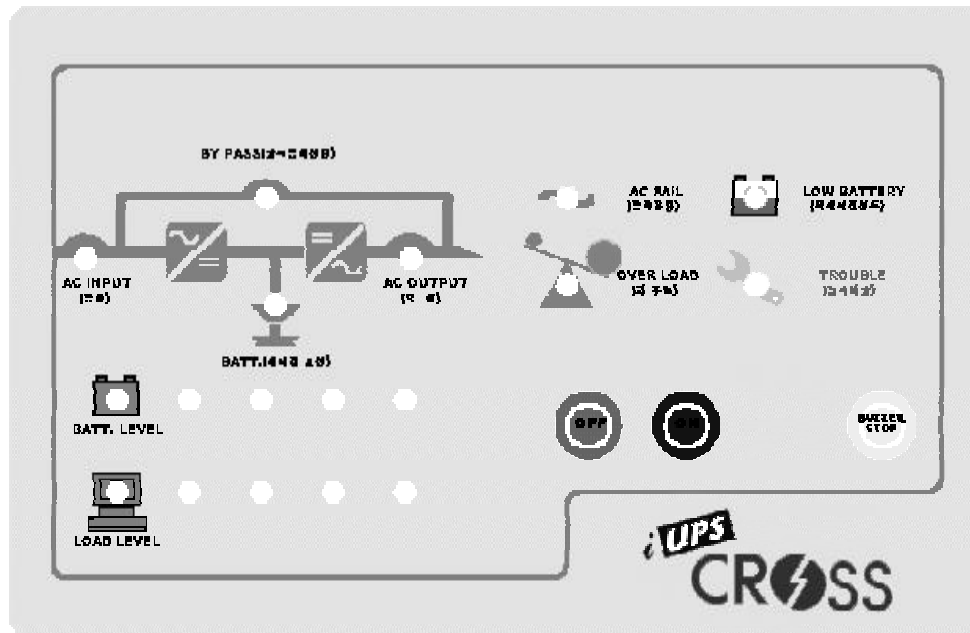

On the front display placed at the top of front side, the buzzer stop switch of equipment to the right end and ON/OFF operation key are mounted. On the top, four LEDs to show the normal operation of equipment are configured.

To the left end, are configured the battery level LED to show the charging level and operation status in the operation of equipment and the load level LED to show load quantity.

In the initial operation of equipment (when connecting input plugs), the alternating input LED (green) and the direct sending LED bypass (amber) on the operation lamp of equipment are flickering.

The On switch(operation switch) is a switch(inverter) to operate equipment and pressing the ON switch, the AC output lamp is flickering.

In the operation of equipment pressing the ON switch, or in the malfunction of equipment or output part, the alarm LED(red) is flickering with alarm sound and so user can immediately recognize the status of equipment.

The left switch is used in the OFF status or malfunction of equipment and pressing the switch, the lamp of AC output returns to the lighting status. Such status is a bypass status. Even at this case, the output of equipment goes out and user can use equipment in its down status when not properly driving equipment in the malfunction of equipment. In this case, user can use load regardless of equipment and enjoy a prompt A/S for that time.(Pay attention as the inverter does not operate in the interruption when using equipment in the bypass status with pressing the OFF switch)

Output Transformer

The output transformer has a special structure including a leakage reactance compound, whose first winding is connected to the inverter and second winding is connected to the output part. This transformer uses the method to include part of output filter functions, which is designed to minimize a high frequency compound and maximize the efficiency of equipment.

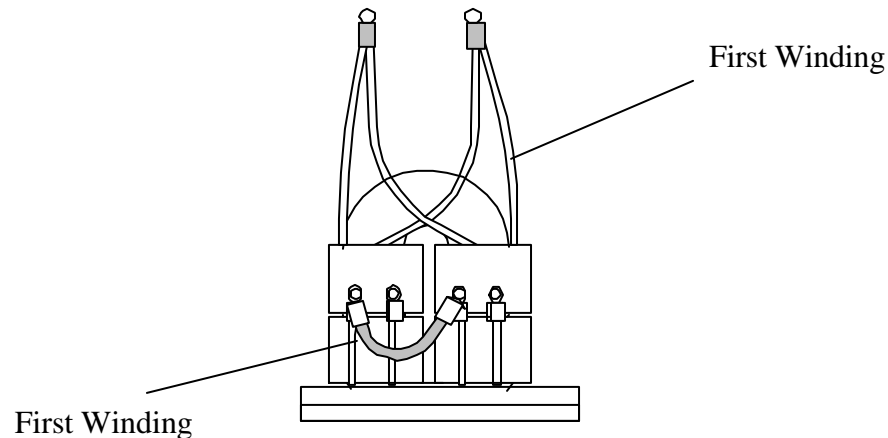

The output transformer is mounted at the bottom base and designed to prevent the quaking of the transformer by firmly tightening the rubber panel between the output transformers with a 7mm bolt.

Rectifier/Charger

This device consists of THYRISTOR MODULE, radiating panel, condenser and all types of part for assembly, etc. The rectifier is a rectifying part to use a single phase wave rectifying circuit and converts alternating current to direct current and provides it to the inverter. On the other hand, the charger is designed with function to charge the condenser at the most suitable condition.

The cooling method of a radiating panel is a compulsory wind cooling method to cool heat with the direct mounting on the radiating panel.

The thyristor module is a device that receives AC current of the input transformer and converts it to DC current. This thyristor module is also a device that charges the condenser with a charger in usual time and that applies the DC from the condenser to the inverter part in the interruption and automatically charges the condenser when recharging is completed.

Thyristor control PCB

The single-phase charger PCB is manufactured to prevent overcharge of the condenser and freely adjust the DC voltage.

Negative Inverter

This device is based on the high frequency switching method which consists of IGBT(Insulated Gate Bipolar Transistor) module, radiating panel and all types of part.

The DC power supplies modules is from IGBT module and detects the sine wave DC power with the inverter based on the SINE PWM method and is designed to prepare a high speed fuse for prevention of semi-conductors at the DC inputting part for preventing of this device.

NEGATIVE INVERTER IGBT MODE

The connection between positive inverter and negative inverter is processed with the galvanized booth bar// to suppress noise. the galvanized booth bar is designed to secure safety with the re-coating of a contraction tube.

Negative Inverter IGBT Control PCB(Base Drive)

The base drive to control the IGBT receives current signals of the control PCB as main PCB and applies voltage of 7V from the base drive to the IGBT gate drive to control the IGBT.

Synchronous Cutoff Part

This device has a structure, which is installed and jointly operated at the bypass (commercial power) part and the inverter part, respectively for preparing the malfunction or overload of the inverter. This device must be also composed of pure semi-conductor element for preventing the surge current occurred due to the phase difference. In addition, this device is manufactured to receive a good quality of stable inverter power as possible as since the overload status is removed in the cutoff with a bypass line due to overload and the device is automatically cutoff with the inverter if the inverter operates properly.

Configuration and Explanation of iUPS

(1) Connection connector for extension of backup

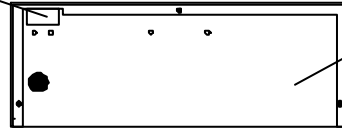

N+1 (Hot swappable extension battery back up).
For the additional mounting of the PoweCell GUARD BATTERY, iUPS allows installation even in the proper operation of equipment and its installation is very simple since the only connection with a PowerCell connector is sufficient.

PowerCell GUARD
(ES 7AH 12V 16Cell of basic mounting type)

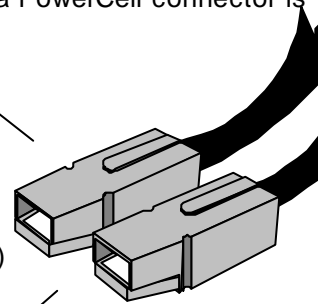

PowerCell Connector

Power Cutoff Lever

Power Breaker

ON
OFF

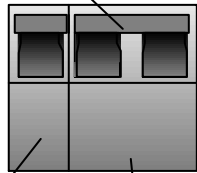

Output Power Cutoff Part

Main Body of i UPS

Connection wire for connecting between PowerCell GUARD and iUPS

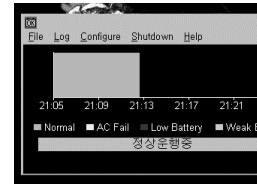

Active screen on Power MonII window

Computer Interface

The installation of Power MonII software on a computer with the basic mounting of a Power MonII hardware can increase efficiency of the automatic shot down and power control of a computer in the interruption.

iUPS Output 220V consent

As powers of consent with two holes are basically mounted, any load equipment can be directly connected and used.

Input power Connection Plug

With only connection of an input plug, users can use this device immediately.

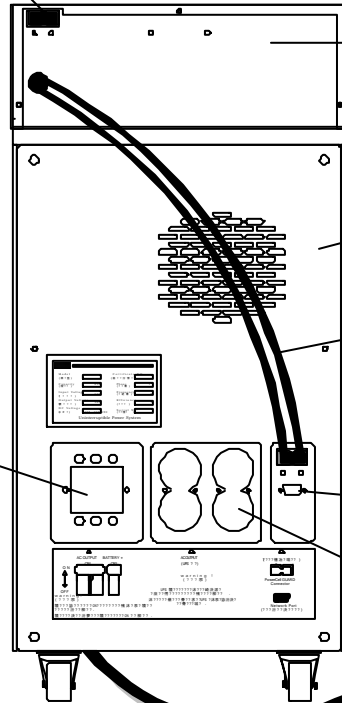

Battery Cutoff Part

(As the battery does not operate if the cutoff lever is OFF status in the interruption, the equipment is down.)

Front Control Display

Operation of inverter indication & output indication lamp.
Pressing the operation ON(button switch) after connecting the input plug, lamp is lighted after a few seconds. In this case, the by-pass indication lamp is extinguished and the lamp is lighted only when pressing the On switch.

Input Defect Alarm Indication Lamp
In the interruption, or in short of the input, or when any problem occurs, the Lamp is lighted and alarms sound rings.

Overload Alarm Indication Lamp
When using more loads than quantities of ups, the lamp is lighted and alarm sound rings.

Battery Low Voltage Alarm Indication Lamp
When over-discharge occurs in the interruption, the lamp is lighted. When life is exhausted and charge is not properly done due to poor charge, the lamps is lighted and alarm sound rings.

Equipment Failure Alarm Indication Lamp when failure of equipment occurs, the lamp is lighted and even in the interruption, the lamp is lighted and alarms sound rings.

Alarm Sound Release Switch
When failure of equipment occurs and alarm sound rings, press this switch in order to release it

ON(inverter operation) switch
Press this switch in order to this inverter.

OFF(By-pass) switch
To stop the inverter and convert it to by pass (usual power) status, press this switch.
Even pressing the OFF switch, output power goes out but the inverter does not drive in the interruption. As all the systems are down for these causes, special attention is needed.

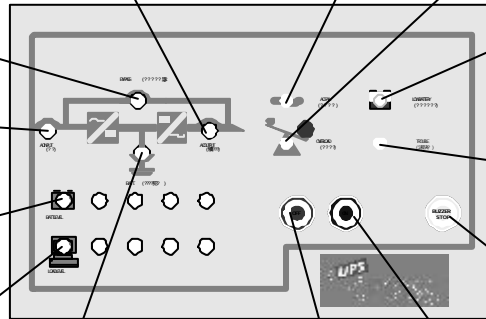

Battery Indication Lamp
Connecting the input power, the lamp is lighted. As the battery is cutoff in the interruption and all loading equipment are down if he battery breaker lever of the power breaker stays at OFF status although the lamp is lighted, always certify the battery cutoff switch.

By-pass indication lamp
Connecting the input plug, the lamp is lighted, and extinguished in the interruption. The output of equipment goes out although not driving equipment in this by-pass status but the output does not go out in the interruption. Thus, drive the inverter always by the ON switch of equipment.

Input Indication Lamp
Connecting the input plug, the lamp is lighted and in the interruption, the input lamp is extinguished.

Battery charge Indication Lamp
Connecting the input power, the lamp is lighted. When the battery is not charged, two or three of the initial charge LED lamp are lighted but all lamps are lighted as time passes.

Load use Indication Lamp
After driving the inverter, the lamp is lighted and the number of lamp increases in proportion of load quantity.